

EcoBlu

Submersible Pump

The C series is 50mm (2") submersible pumps for clean and dirty water. C pumps have a solid stainless steel body, cast iron pump casing and an impact resistant PVC stainer base for durability during robust handling. The vortex impeller offers excellent wear resistance in site applications where the water contains sand and silt in suspension, thus maintaining performance and reliability.

It has a stainless steel shaft, that is fitted with an ultra hardwearing, silicon carbide, double mechanical seal (in an oil chamber), and has a stirring device to reduce blockages. Available with an optional float switch. C. 50mm site drainage pump is an ideal small and robust submersible contractor's pump with a wide range of applications where-ever water has to be moved.

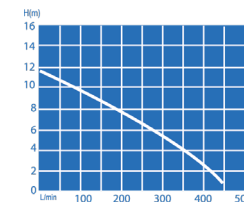
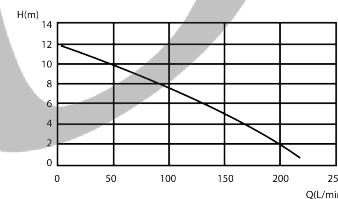
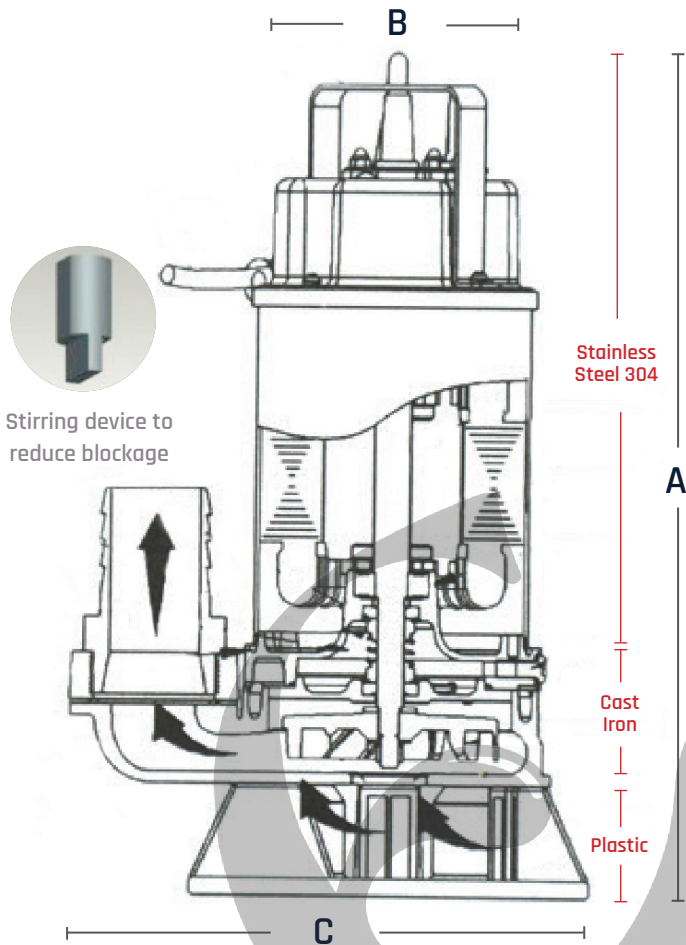

Diagram C-450

Model	Dimension (mm)		
	A	B	C
C-217	370	130	240
C-450 & C-450Auto	385	140	240

Model	Code	Max Output (L/H)	Max Head (m)	Output Power (Watt)	Outlet Connection	Phase	Wire Length (m)
C-217	P-7803	13,020	12	400	2"	1	5
C-450	P-7888	27,000	12	750	2"	1	5
C-450 Auto	P-7889	27,000	12	750	2"	1	5